

# ROBUS®

QUALITY PRODUCTS BY LED GROUP

## 5W GU10 LED LAMP 55MM, DIMMABLE R50GU10D-WW R50GU10D-CW

Please read instructions before commencing installation and retain for future reference.

### Specification:

Model No.	R50GU10D-WW	R50GU10D-CW
Supply Voltage:	220-240V~50/60Hz	220-240V~50/60Hz
Power Consumption:	5W	5W
Lumen Output:	375lm	425lm
Colour Temperature:	2700-3300k	4000-4500k
CRI:	>80	>80
Beam Angle:	38°	38°
Operating Temp Range:	-10°C ~ 30°C	-10°C ~ 30°C
IP Rating:	IP20	IP20
Safety Classification:	Class II	Class II
Overall Diameter:	50mm	50mm
Depth:	55mm	55mm
Weight:	0.06kg	0.06kg
Warranty:	2 year	2 year

Dimmable by leading or trailing edge phase dimmer.

ATTENTION: Don't touch lamp when it is on. Use only in equipment of which the specifications suit with this lamp type. Switch off power when replacing lamp.

### Installation:

**! Electrical products can cause death or injury, or damage to property. If in any doubt about the installation or use of this product, consult a competent electrician.**

- 1 Ensure mains supply is switched off before commencing work.
- 2 Safety note! The power supply cord must not be exposed to mechanical damage.
- 3 Remove existing lamp and replace with energy LED
- 4 Use only with a mains supply that is protected by a Miniature Circuit Breaker (M.C.B.)

Note: Before installation please be aware of maximum operating temperature. High temperature environments will have a detrimental effect on lamp life. Not suitable for installation where ambient room temp is above 30°C

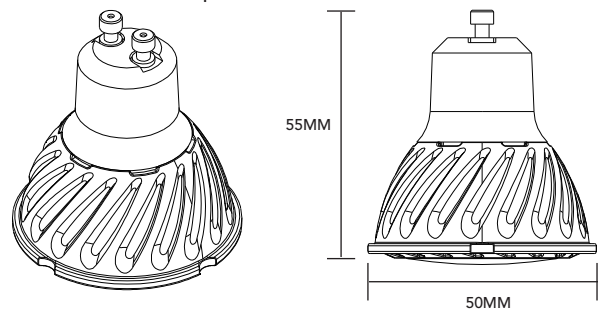

### Information for the Product user

1. Please note the requirement to dispose of Waste Electrical & Electronic Equipment separately from household waste (WEEE marked with crossed out wheelee bin symbol).
2. Please consider your role in contributing to re-use and recycling by returning this product at end of life to a collection centre for waste electrical equipment or a Civic Amenity site, or to a retail outlet from which you are purchasing a replacement.
3. This equipment may contain substances that are hazardous to health and the environment if disposed of carelessly. It is important that it is separated from normal household waste and recycled in the WEEE chain
4. The "crossed out wheelee bin symbol" on a product indicates this equipment must not be disposed of in normal household waste, but should be disposed of according to local WEEE regulations

### The Installation must be carried out by an electrician

#### LED Group

Western Retail Park  
Nangor Road  
Dublin 12  
Ireland

Tel: +353 1 7099000  
Fax: +353 1 7099060  
Email: info@led.ie  
Website: www.led.ie

